

Item	Type	Min Qty.
Wetpour (m2)	FFH 1.0 m	29.37
Wetpour (m2)	FFH 1.5 m	7.55
Wetpour (m2)	FFH 1.75 m	8.99
Unit Fix (m3)	1:2:4 Concrete	0.66
Surfacing Base (m3)	MOT Type 1	4.40
Length of Edging (m)	Perimeter	25.51

ESTIMATED QUANTITIES ONLY

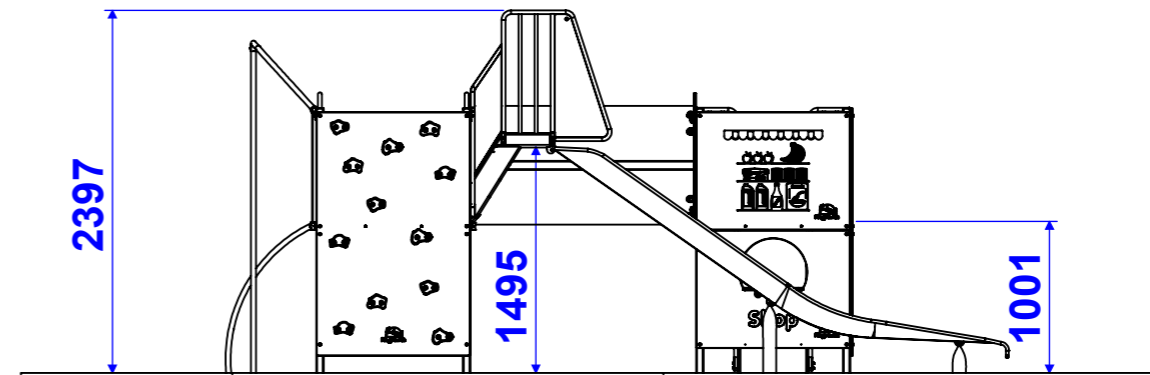

Drawing Status	Insert Document

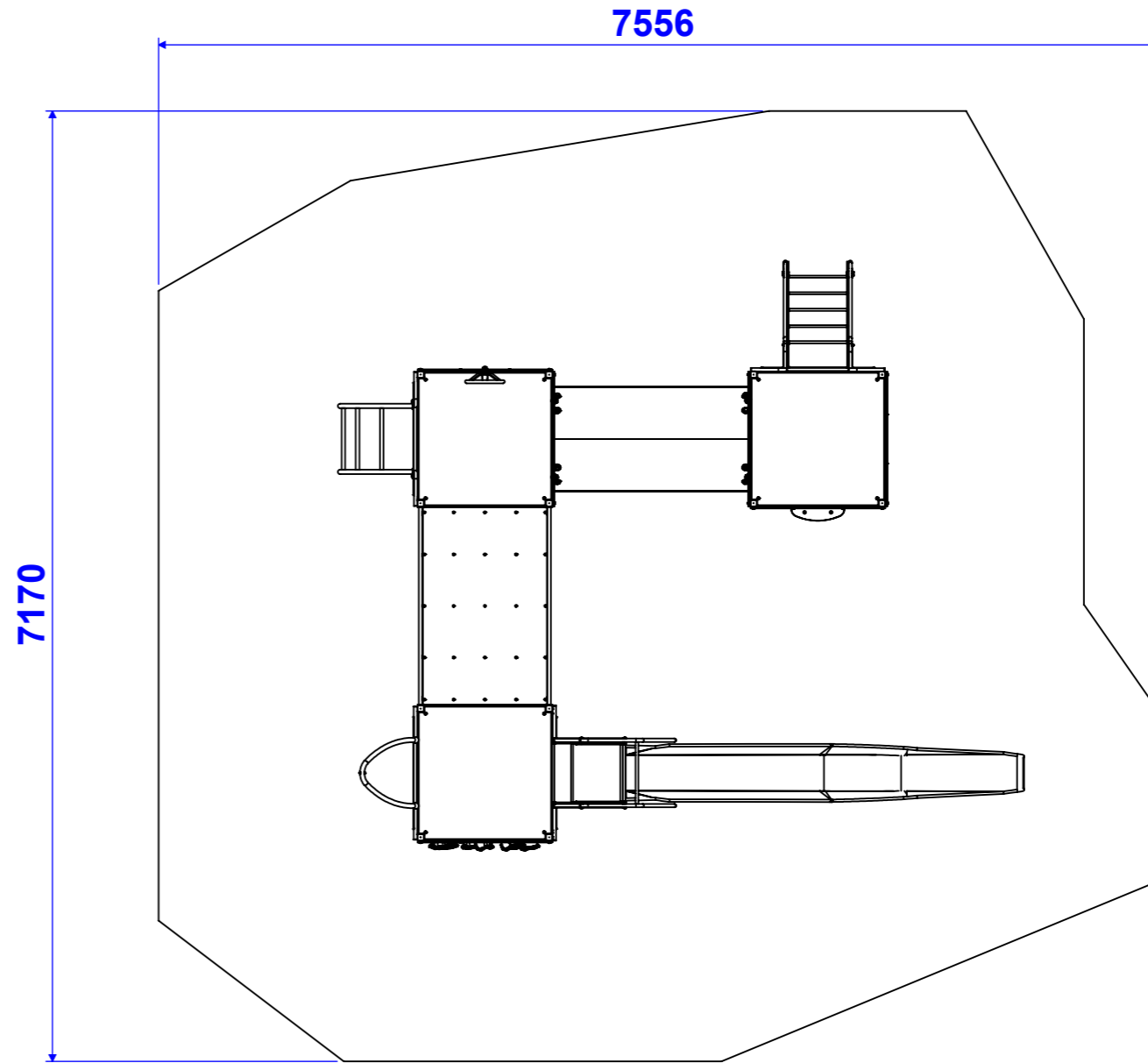

Design
 Manufacture
 Installation
 www.gljones-playgrounds.co.uk
 info@gljones-playgrounds.co.uk

GL Jones Playground Ltd
 Station Road, Bethesda
 Gwynedd LL57 3NE
 Tel: 01248 600372
 Fax: 01248 602085

THIS DRAWING SHOULD NOT BE USED FOR INSTALLATION PURPOSES. FOR GUIDENCE ONLY

DO NOT SCALE DRAWING	REVISION	00
TITLE: Snowdon Unit		
MATERIAL: See Detail Drawing	DWG NO. H021-002	A3 ©
Website Views		

LASTSAVE	NAME	DATE
DRAWN	nathan.williams	24/09/2024