

Item	Type	Min Qty.
Wetpour (m ²)	FFH 0.6 m	18.63
Unit Fix (m ³)	1:2:4 Concrete	0.25
Surfacing Base (m ³)	MOT Type 1	1.81
Length of Edging (m)	Flat Top PCC	16.56
Edging Fix (m ³)	1:2:4 Concrete	0.5

INSTALLER: Must read through installation instructions provided!!!!

ESTIMATED QUANTITIES ONLY

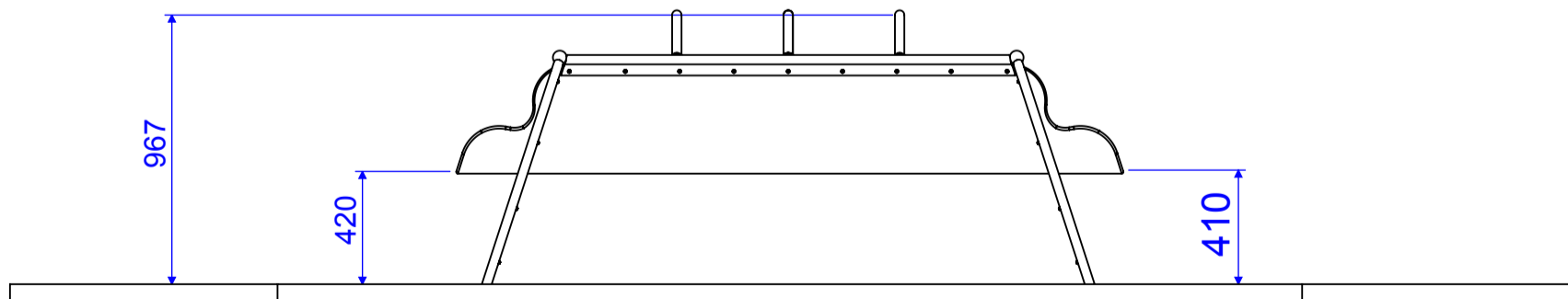
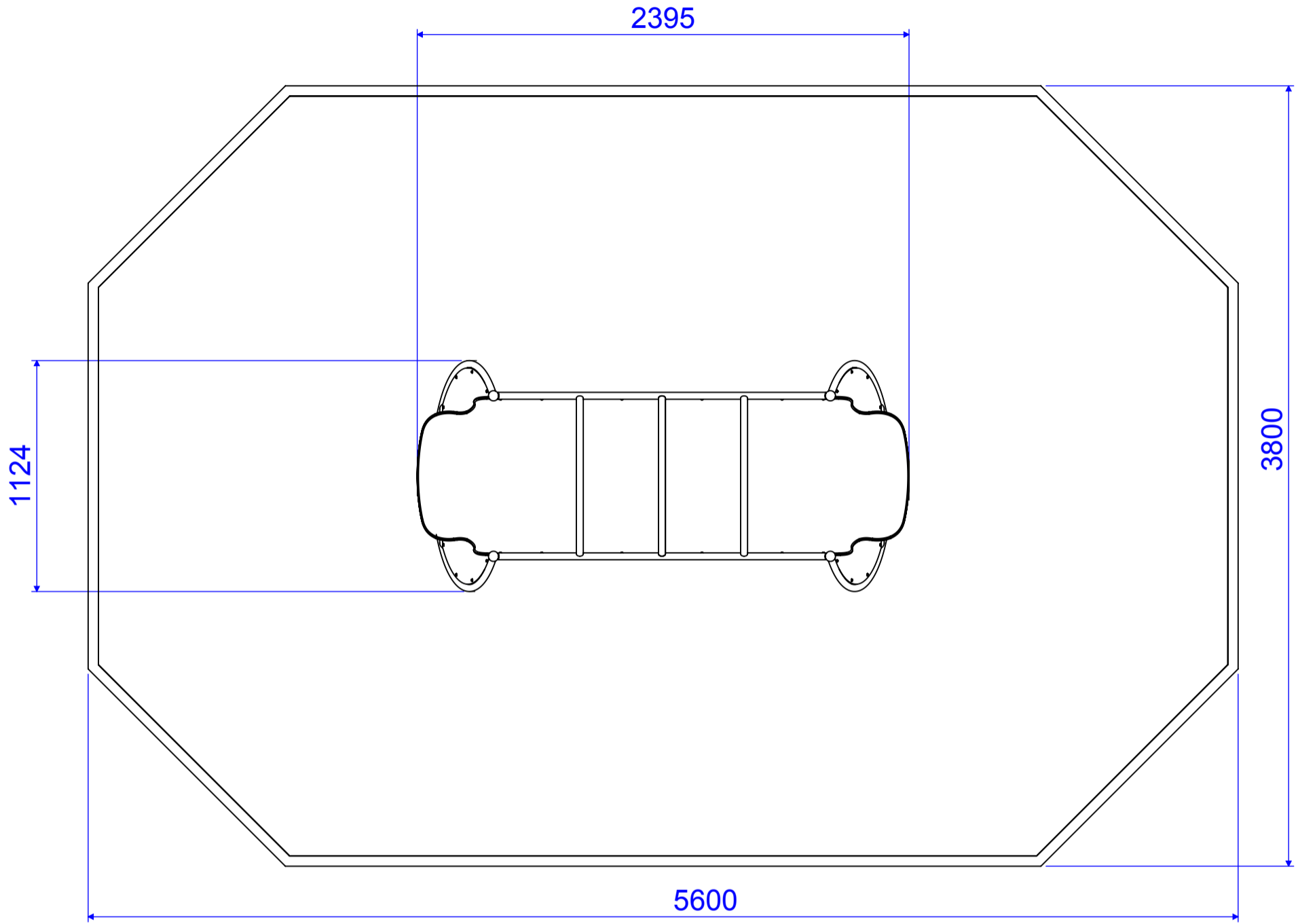

Current Drawing Status	Prototype
Manufacturing Manual	60



GL Jones Playground Ltd
 Station Road, Bethesda
 Gwynedd LL57 3NE
 Tel: 01248 600372
 info@gljones-playgrounds.co.uk
 www.gljones-playgrounds.co.uk

	NAME
LASTSAVE	mathew.jones
DRAWN	N. Williams

DO NOT SCALE DRAWING

REVISION 02

TITLE: Ability Pull Slider

This Drawing should **NOT** be used for Installation purposes. For Guidance Only

DWG NO.	A3
S001-001	©
FILE NAME S001-001 - Ability Pull Slider	
DATE 10/12/2016	SHEET 2

This drawing must not be copied or passed on to a third party without the specific permission of G.L. Jones Playgrounds Ltd. This drawing is supplied on the understanding that the installer has the required skills to ensure correct installation - G.L. Jones Playgrounds Ltd can only guarantee installations completed under their direct supervision.